

RCP200

SERIES 1/4 - 5 HP Regenerative DC Motor Controls

General Description

The Regenerative Control Package RCP200 Series of D.C. motor controls provides full wave four quadrant regenerative speed or torque control for 1/4 through 5 HP shunt wound and permanent magnet D.C. motors. Designed for performance and quality, but remaining versatile and functional, the RCP200 provides the OEM and panel builder with maximum design capability.

Two units cover the full horsepower range. Also, three contractor models are available with armature contractor, dynamic braking and start/stop logic.

Innovative design techniques have eliminated normal problem areas often associated with multi-bridge designs necessary for regenerative control. These design techniques combined with Carotron's standard quality features result in a motor control possessing the highest level of performance.



Standard Features

- Inner current loop for fast, stable response to load change
- Metal film resistors and cermet pots for temperature stability
- I.C. regulated power supplies
- High frequency multi-pulse gating
- Conservative power module rating
- R-C decoupling of signal level inputs for superior noise rejection
- A.C. line fuses
- Line Mov and snubber for transient protection
- Functional terminal strip labeling and logical P.C. board layout
- Independent adjustable linear acceleration and deceleration in both the forward and reverse direction Independent max speed for forward and reverse direction
- Independent current limit for forward and reverse direction
- Deadband adjustment
- Adjustable IR compensation
- Current range selectable by jumper
- Speed/torque mode selectable by jumper
- Armature or tachometer feedback selectable by switch
- 7 or 50 VDC per thousand RPM tach feedback selectable by jumper

Specifications

A.C. INPUT

115 VAC \pm 10%, 50/60 Hz \pm 2 Hz
230 VAC \pm 10%, 50/60 Hz \pm 2 Hz

ARMATURE OUTPUT

0- 90 VDC for 115 VAC input
0-180 VDC for 230 VAC input

FIELD OUTPUT

100 VDC @ 1 Amp for 115 VAC input
200 VDC @ 1 Amp for 230 VAC input

HORSEPOWER RANGE

Model RCP202

1/4 - 1 HP @ 115 VAC input
1/2 - 2 HP @ 230 VAC input

Model RCP205

1/4 - 1 HP @ 115 VAC input
1/2 - 5 HP @ 230 VAC input

SPEED REGULATION

Armature feedback: \pm 1.0% of base speed
Tachometer feedback: \pm 0.5% of base speed

TORQUE REGULATION

\pm 2% of range selected

ADJUSTMENTS

- Max speed: -20 to +10% of full base speed
- Current limit: 0 to 190% of current range
- IR Compensation: range set by current range jumper
- ACCEL and DECEL: linear, independently adjustable forward and reverse, 2 ranges, 1-5 sec. or 4-40 sec.

SPEED RANGE

20:1, motor dependent

TEMPERATURE

Chassis - 0 to 55 C
Enclosed - 0 to 40 C

Standard Models and Descriptions

115 VAC input	230 VAC input	Model number	Description	Approx. Shpg. Wt.	Dim.	Conn.
1/4 - 1 HP	1/2 - 2 HP	RCP202-000	Chassis Only, Basic model	9 lbs.	Fig. F.1	Fig. F.3
1/4 - 2.5 HP	1/2 - 5 HP	RCP205-000	Chassis Only, Basic model	9 lbs.	Fig. F.1	Fig. F.3
1/4 - 1 HP	-	RCP202-BC1	Armature Contact Chassis Model with Start, Stop and D.B.	18 lbs.	Fig. F.2	Fig. F.4
-	1/2 - 2 HP	RCP202-BC2	Armature Contact Chassis Model with Start, Stop and D.B.	18 lbs.	Fig. F.2	Fig. F.4
-	1/2 - 5 HP	RCP205-BC2	Armature Contact Chassis Model with Start, Stop and D.B.	18 lbs.	Fig. F.2	Fig. F.4

Dimensions

Chassis Only Models

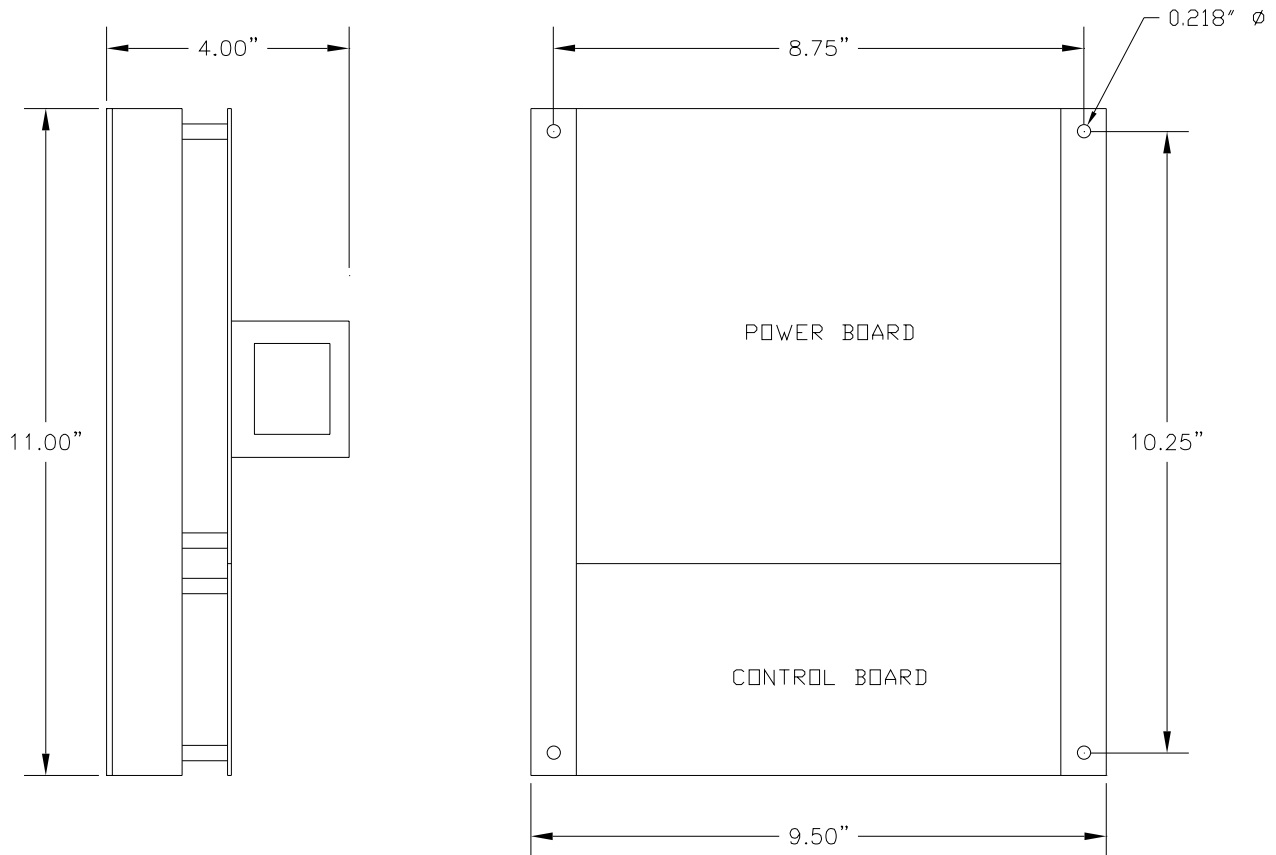

Fig. F.1

Dimensions

Contactor Models

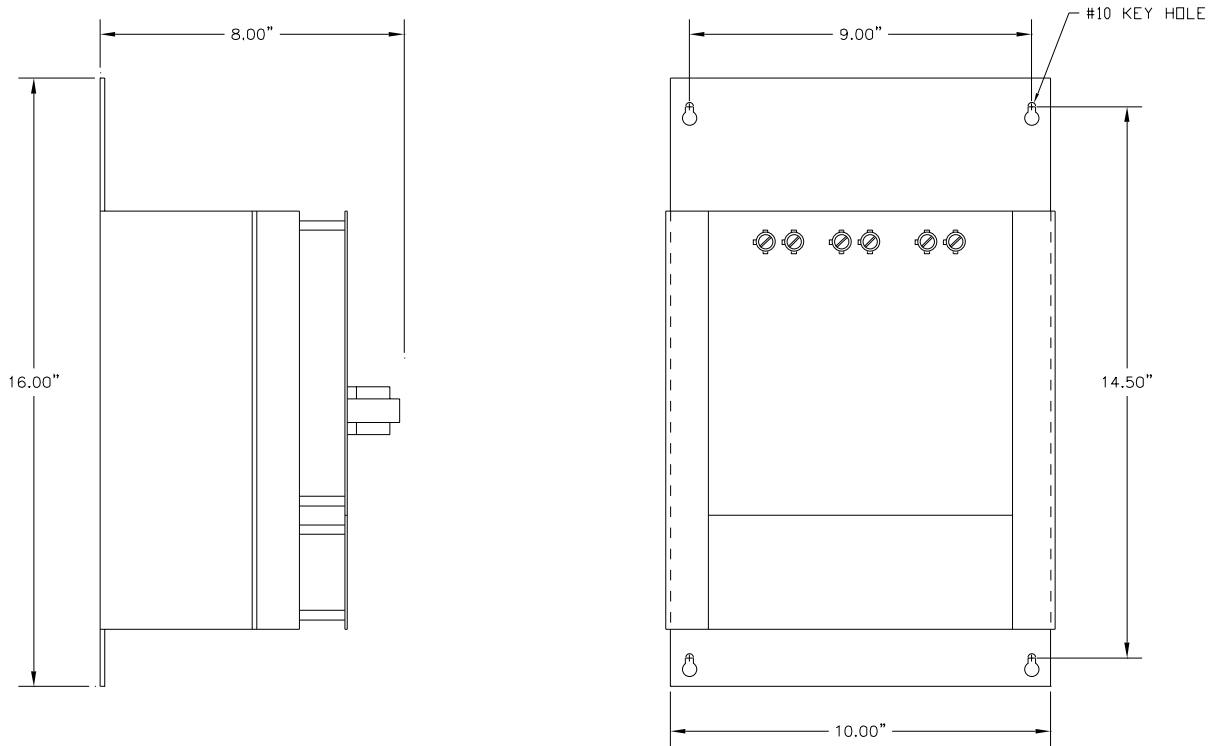

Fig. F.2

Connections

Chassis Only Models

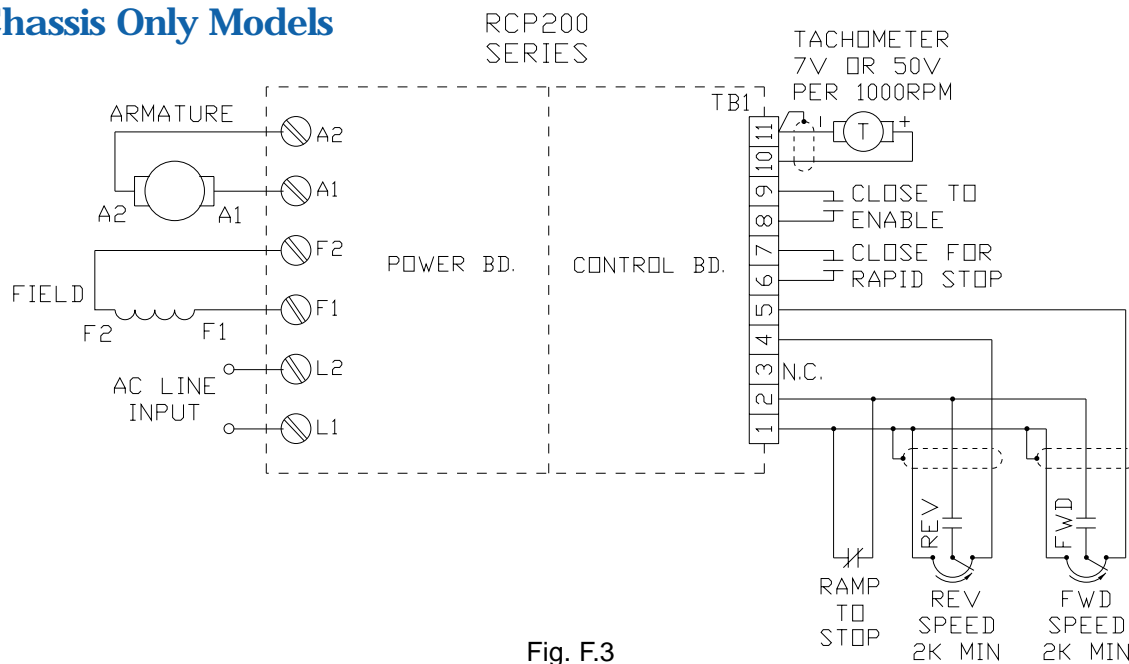

Fig. F.3

Contactor Models

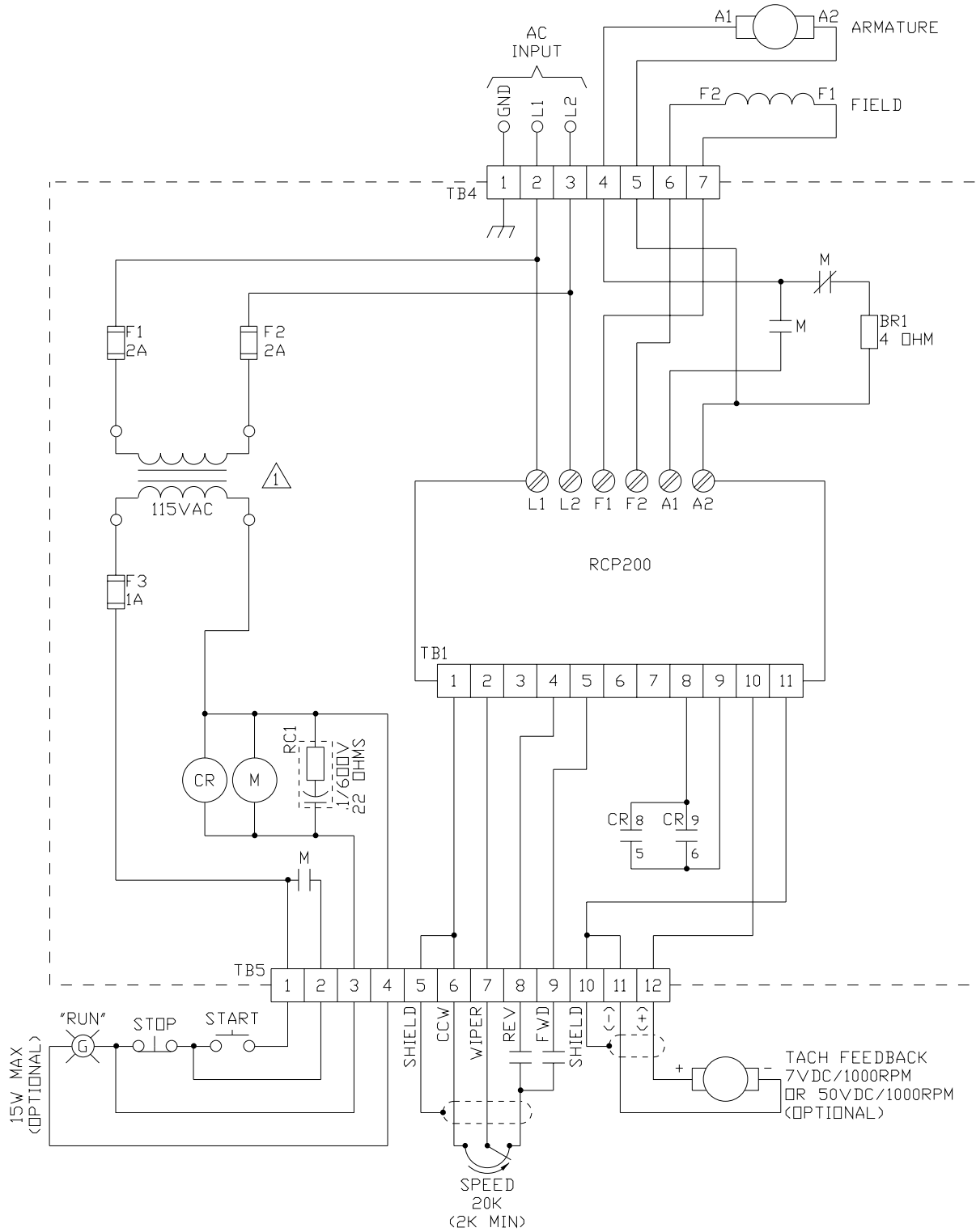

Fig. F.4